SICE Annual Conference 2020

Guidance of Company Exhibition

SICE

The Society of Instrument and Control Engineers

SICE Annual Conference 2020 Organizing Committee

<http://www.sice.jp/siceac/sice2020/>

SICE2020 Company Exhibition Session

The Society of Instrument and Control Engineers
SICE2020 Organizing Committee

October 2019

Dear colleagues,

We are delighted to invite you to the SICE2020 company exhibition, “**The SICE2020 special project: Exhibition on Technologies for Exciting Innovations for Smart Societies**”, at the Empress Convention Center & Empress Hotel (Chiang Mai, Thailand) which will take place in September 2020, during the SICE Annual Conference 2020.

At the company exhibition held in Hiroshima, Japan during SICE2019, eighteen exhibitions were displayed and more than 600 participants actively discussed and exchanged information. The company exhibition in 2020 will also attract a lot of participants. This exhibition is a great opportunity to showcase your advanced technologies and network with specialists in a wide range of fields.

To exhibit or sponsor SICE2020, please kindly fill out the application form below and send it back to the SICE administration office by mail before 10 July 2020.

We hope you will be able to join us for this special project. If you have any questions about this event, please email the SICE administration office.

Regards,

Tetsuo Sawaragi (Kyoto University, Japan)
SICE President

Kou Yamada (Gunma University, Japan)
Kosin Chamnongthai (KMUTT, Thailand)
SICE2020 General Co-chairs

1. **Date and time:** 24-26 September 2020, 9:00am to 5:00pm
2. **Location:** Empress Convention Center & Empress Hotel, Chiang Mai, Thailand
3. **Exhibition's theme:** Exhibition on Technologies for Exciting Innovations for Smart Societies
4. **Display materials:** Details are shown in the subsequent pages.
5. **Registration fees:** Details are shown in the subsequent pages.

SICE contact information (please mail your application form to the following address.)

Name: K. Suzuki

Address: SICE administration office, 4F Kaneko Bldg. 1-11-9 Kandaogawamachi, Chiyoda-ku, Tokyo
101-0052 Japan

Email: k_suzuki@sice.or.jp

Event summary

1. Session

Conference period 23 – 26 September, 2020

Exhibition period 24 – 26 September, 2020

Installation Wednesday, 23 September, 2020 13:00 to 16:00 (TBD)

Exhibition Thursday, 24 September, 2020 9:00 to 17:30 (TBD)

Friday, 25 September, 2020 9:00 to 17:30 (TBD)

Saturday, 26 September, 2020 9:00 to 13:00 (TBD)

Removal Saturday, 26 September, 2020 13:00 to 16:00 (TBD)

2. Exhibition hall

The Empress Hotel Convention Center

199/42 Chang Klan Road, Chiang Mai 50100, Thailand

2F lobby, exhibition hall

<http://www.empresshotels.com/ecc>

The exhibition hall is located in front of conference rooms so that a lot of participants will visit your booths.

3. Venue access

From Japan to Chiang Mai Airport

From Tokyo, Nagoya, Osaka and Fukuoka via Bangkok, Beijing, Hong Kong, Taiwan, Seoul and Singapore.

From Chiang Mai Airport to the venue

About 15 min by taxi (CHIANGMAI AIRPORT TAXI).

Shuttle minibuses are available at reasonable fares for the guests of the 4-star Empress Hotel and the 5-star Empress Premier Hotel.

<https://sice.jp/siceac/sice2020/travel.html>

4. Exhibition items

Control Applications (Automated cars, Trains, Aircrafts, Industrial plants, etc.), Robot-related products and materials, Measurement instruments, Sensors, Actuators, Controllers, Analysis software, Educational software, Information instruments, Machine tools, Medical equipment and other products and services relating to System, Information, Measurement and Control.

Exhibition

1. Exhibition booth (large)

- **Benefits:** The booth size is large enough to display a car.
One technical presentation for free.
- **Equipment:** Stand 3.5m, backboard 3.0m,
two exhibition tables and chairs (TBD).
- **Power supply:** AC220V, about 300W per booth
(TBD, contact us for details).

- **Registration fee (excl. tax):**

SICE supporting member ¥100,000,

Non-member ¥120,000, University ¥50,000.

- ※ The fees include a SICE2020 registration fee and a banquet ticket for ONE delegate.

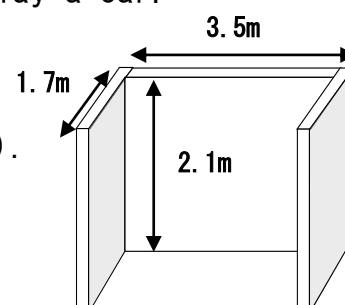

- Two tables with
W 1.5m × D 0.6m.
- Two chairs.

Exhibition booth (L)
(TBD)

2. Exhibition booth (small)

- **Benefits:** One technical presentation for free.
- **Equipment:** Stand 1.5m, backboard 1.2m,
an exhibition table and a chair (TBD)
- **Power supply:** AC220V, about 300W per booth
(TBD, contact us for details).

- **Registration fee (excl. tax):**

SICE supporting member ¥50,000,

Non-member ¥60,000, University ¥25,000.

- ※ The fees do not include delegators' SICE2020 registration fees. To attend SICE2020 conference sessions and/or give a presentation, please register and pay the SICE2020 registration fee.

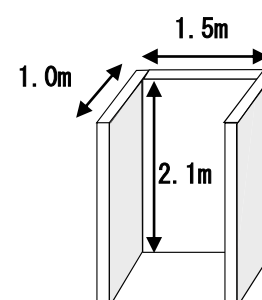

- One table with
W 1.2m × D 0.45m.
- One chair.

Exhibition booth (S)
(TBD)

3. Poster exhibition

- **Equipment:** One panel for an A1-sized poster.
- **Registration fee (excl. tax):**

SICE supporting member ¥20,000,

Non-member ¥30,000, University ¥10,000.

※ The organizing committee will not post or remove posters for the exhibitors.

4. Book exhibition

- Registration fee (excl. tax):
SICE supporting member ¥30,000,
Non-member ¥40,000.

[Note] Each of the exhibitors must pay all the costs necessary for installation and removal of their exhibits.

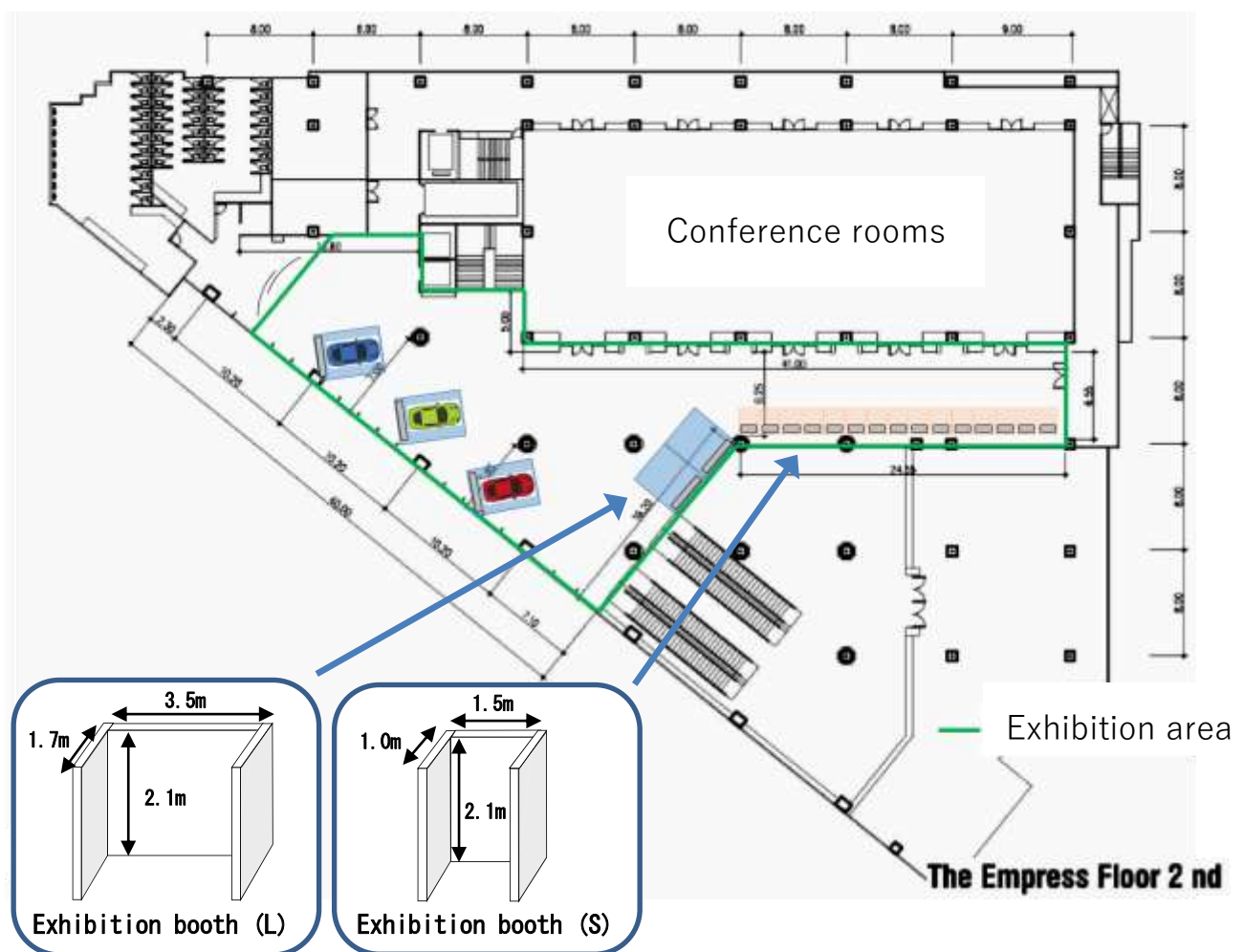

Layout of the exhibition area

- ※ There is an entrance for installation and removal of cars for display.
- ※ The layout of the exhibition area is subject to change.

Exhibition events

1. Technical presentations

- Each technical presentation will be held at the end of a regular conference session. The duration of the presentation is 15 min. Although in principle, the committee will allocate presentations to suitable slots, they will try to adjust the schedule upon request.
- The basic registration fees for Exhibition booth (L) and Exhibition booth (S) include the charge for one presentation. An optional package is available to increase the number of presentations.
- Presentation in Japanese is acceptable. However, it is recommended to prepare the presentation materials in English.

2. Stamp rally

- The participants will visit each booth and collect the stamps from the exhibitors.
- It is highly appreciated if you could provide promotional giveaway items/gifts/token for the participants.

Advertising and sponsorship opportunities

1. Advertising in the conference proceedings

The company's advertisement will be printed in the conference proceedings. Color (limited to the first two companies only) or black and white; a banner on the SICE2020 website is included for an A4 ad.

- **Materials to submit:** Advertising content/banner image.
- **Registration fee (excl. tax):**
(Color) SICE supporting member ¥180,000, non-member ¥200,000.
(Black & white) SICE supporting member ¥100,000, non-member ¥120,000.

2. Flyers

The company's one-page flyer will be inserted in each conference bag.

- **Materials to submit:** A4 flyers.
- **Registration fee (excl. tax):**
SICE supporting member ¥30,000, non-member ¥50,000.

3. Website banner

The company's banner advertisement will be posted on the SICE2020 webpage.

- **Materials to submit:** Banner image.
- **Registration fee (excl. tax):**
SICE supporting member ¥50,000, non-member ¥80,000.

4. USBs for proceedings

The company name and logo will be printed on the USBs of the conference proceedings (limited to the first applicant only).

- **Materials to submit:** Company logo image.
- **Registration fee (excl. tax):** SICE supporting member ¥150,000.

5. The conference bags

The company name and logo will be printed on the conference bags.

- **Materials to submit:** Company logo image.
- **Registration fee (excl. tax):**
SICE supporting member ¥100,000, non-member ¥120,000.

6. Supporting coffee break corners

The company name and logo will be displayed at coffee break tables.

- **Materials to submit:** Company logo image.
- **Registration fee (excl. tax):**
SICE supporting member ¥50,000 per minimum amount,
non-member ¥50,000 per minimum amount.

7. Social Program Sponsorships

Sponsorships are available for the social programs listed below. It will be broadly announced in the conference proceedings and other media that the social programs are sponsored by the companies. The representative of each sponsorship will be given an opportunity to give a speech during the sponsoring social program activity. (Each of the fees listed below includes a SICE2020 registration fee for ONE person. Each sponsorship is exclusive to one company only on a first come basis.)

- **Welcome Reception (23 September)**

Fee (excl. tax): SICE supporting member ¥400,000, non-member ¥500,000.

- **Banquet (25 September)**

Fee (excl. tax): SICE supporting member ¥600,000, non-member ¥800,000.

- **Closing Tour (26 September)**

Fee (excl. tax): SICE supporting member ¥400,000, non-member ¥500,000.

SICE2020 Company Exhibition Application Form

◇ Exhibition stands, poster exhibitions and book exhibitions

Category (select one checkbox)	Description	Registration fee (Japanese yen • excl. tax)		
		SICE supporting member	Non- member	University
Exhibition stand: large (*2)	Display and presentation (*1); width of the stand: 3.5 m, size of the back board: 3.0 m; two tables and chairs are provided (TBD).	¥100,000	¥120,000	¥50,000
Exhibition stand: small (*3)	Display and presentation (*1); width of the stand: 1.5 m, size of the back board: 1.2 m; a table and a chair are provided.	¥50,000	¥60,000	¥25,000
Poster exhibition	One panel for an A1-sized poster.	¥20,000	¥30,000	¥10,000
Book exhibition	Book exhibition and sales.	¥30,000	¥40,000	n.a.

(*) Everyone can join the welcome party on Wednesday 23 September (free of charge). To attend the banquet on Friday 25 September, one must register and pay an additional fee. The fee for the banquet is not included in the basic fees shown in the above table.

(*1) Each technical presentation will be held at the end of a regular conference session. The duration of the presentation is 15 min. Although in principle, the committee will allocate presentations to suitable slots, they will try to adjust the schedule upon request.

- Each of the basic registration fees includes the charge for one 15 min presentation.
- An optional package is available to increase the number of presentations (see the next page for details).
- Presentation in Japanese is acceptable. However, it is recommended to prepare the presentation materials in English.

(*2)

(*3) The fees do not include delegators' SICE2020 registration fees. To attend SICE2020 conference sessions and/or give a presentation, please register and pay the SICE2020 registration fee.

※ Optional packages are given in the next page.

◇Exhibition optional packages

Category (multiple choices are allowed; in case of too many applications, we will adjust your choices.)	Description	Registration fee (Japanese yen • excl. tax)			Materials to submit
		SICE supporting member	Non-member	University	
Advertising on the conference proceedings	Color (limited to the first two companies only) or black and white; a banner on the SICE2020 website is included for an A4 ad.	Color ¥180,000 Black & white ¥100,000	Color ¥200,000 Black & white ¥120,000		Advertising content / banner image
Flyer	One-page flyers in the conference bags.	¥30,000	¥50,000		A4 flyer
Website banner ad	A banner on the SICE2020 website	¥50,000	¥80,000		Banner image
Advertising on USBs for proceedings	Advertising by printing the company name and logo on the USBs of the conference proceedings. ※Limited to the first applicant only.	¥150,000			Company logo image
Advertising on the conference bags	Advertising by printing the company name and logo on the conference bags.	¥100,000	¥120,000		
Supporting coffee break corners	Displaying the company name and logo at coffee break tables.	The minimum amount is ¥50,000.	The minimum amount is ¥50,000.		
Stamp rally	It is highly appreciated if you could provide promotional giveaway items/gifts/token for the participants.	<input type="checkbox"/> I will register for the stamp rally and provide company's promotional giveaway. <input type="checkbox"/> I will not register for the stamp rally.			
Technical presentation (Additional application)	Charge for additional presentations. Note that each basic fee already includes one presentation.	¥20,000 per presentation	¥20,000 per presentation		
Welcome reception sponsor (23 September)	Sponsorships for the welcome reception, banquet and closing tour will be broadly announced in the conference proceedings and other media. The representative of each sponsorship will be given an opportunity to give a speech during the social program. (Each fee includes a SICE2020 registration fee for ONE person. Each sponsorship is EXCLUSIVE TO ONE COMPANY ONLY on a first come basis.)	¥400,000	¥500,000		
Banquet sponsor (25 September)		¥600,000	¥800,000		
Closing Tour sponsor (26 September)		¥400,000	¥500,000		

Total amount : ¥ **(excluding tax)**

I will apply for the company exhibition as described above.

Contact information/billing address

Company's name	
Department/division	
Name	 Please stamp here.
Postal address	
Telephone number	
Email address	